

Guidelines on Procurement Procedures in Aided Schools

(Updated in October 2025)

Contents

Introduction	1
Prevention of Bribery Ordinance	1
Safeguarding National Security	1
Declaration of Conflict of Interest	2
Segregation of Duties	2
Principle of Fairness	2
Security of Information	3
Procurement Procedures	3
<i>For procurement at an estimated cost of up to \$50,000 each</i>	
<i>For procurement at an estimated cost of more than \$50,000 each</i>	
Single Quotation/Tendering	9
Involvement of School Sponsoring Bodies in Schools' Procurement Activities	10
Sub-contracting	11
Services from Social Enterprises	11
Supplies Inspection Team	12
Other Useful References	12
Summary Workflow	13
Annexes	15

Introduction

This set of Guidelines aims to facilitate schools to ensure that schools' day-to-day procurement is properly and efficiently handled and that available resources are utilised to the best advantage. This set of Guidelines is generally based on the procurement and supplies procedures currently applicable to Government Departments and is formulated in consultation with the Independent Commission Against Corruption (ICAC). All aided schools are required to strictly follow the procedures set out in this set of Guidelines. At all times, SMCs/IMCs should ensure that their schools have put in place a fair, open and transparent system of procurement procedures and there are adequate checks and balances to prevent favouritism, corruption and malpractices.

2. Schools are strongly advised to report to the SMCs/IMCs, on an annual basis, of any irregularities in the procurement procedures by completing the “Exception Report on Procurement Activities for Aided Schools” available on the Education Bureau (EDB) homepage [<http://www.edb.gov.hk/en/index.html> (*EDB homepage → School Administration and Management → Regulations → Checklist on Common Administrative Issues in Aided Schools*)].

Prevention of Bribery Ordinance

3. It is an offence under the Prevention of Bribery Ordinance that, without lawful authority or reasonable excuse, school staff accept advantages from suppliers and contractors or the suppliers and contractors offer advantages to school staff in connection with school procurement. Schools must not permit their staff to receive advantages (including payment of commission) from suppliers and contractors. They should also inform all suppliers and contractors in writing that the offer of such advantages to school staff in connection with their official duties is illegal. This could be done by incorporating a statement in the order form or the terms of quotations/tenders. In any case, schools must not allow the choice of suppliers and contractors to be in any way influenced by any form of advantages, including donations.

4. School staff who use false accounting records (e.g. bogus quotations) or falsify documents with intent to deceive their school shall be guilty of an offence under the Prevention of Bribery Ordinance.

Safeguarding National Security

5. It is the constitutional duty for the Hong Kong Special Administrative Region to safeguard national security. School staff of all levels must effectively prevent and suppress any act or activity endangering national security. Schools should exercise their professional judgement, maintain a high degree of sensitivity and prudently assess any potential national security risks or issues that may be involved in every stage of the procurement.

6. To this end, schools should incorporate the following specific clauses into the quotation/tender documents to allow disqualification of a supplier and to terminate the contract in the interest of national security:

- (a) Notwithstanding anything to the contrary in the quotation/tender documents, the school reserves the right to disqualify a supplier on the grounds that the supplier has engaged, is engaging, or is reasonably believed to have engaged or be engaging in acts or activities that are likely to cause or constitute the occurrence of offences endangering national security or otherwise the exclusion is necessary in the interest of national security, or is necessary to protect the public interest of Hong Kong, public morals, public order or public safety.
- (b) The school may immediately terminate the contract upon the occurrence of any of the following events:
 - (i) the contractor has engaged or is engaging in acts or activities that are likely to cause or constitute the occurrence of offences endangering national security or which would otherwise be contrary to the interest of national security;
 - (ii) the continued engagement of the contractor or the continued performance of the contract is contrary to the interest of national security; or
 - (iii) the school reasonably believes that any of the events mentioned above is about to occur.

Declaration of Conflict of Interest

7. Staff involved in procurement and supplies duties should be required to sign an undertaking that they would declare in writing to the SMCs/IMCs any close connection that they currently or in future have with suppliers or contractors (e.g. being relatives, employers, shareholders) as soon as they become aware of it. Schools are required to properly record any declarations (a standard form is provided at **Annex I** for reference) or disclosures made and necessary action taken to avoid any actual or perceived conflict of interest. The staff declaring conflict of interest have to refrain from processing the related quotation/tender or follow the instruction of SMCs/IMCs. **This requirement should be annually brought to the notice of the staff involved by means of a circular which they should be required to sign to indicate that they have read and understood it.**

Segregation of Duties

8. To strengthen checks and balances, a clear segregation of staff duties is essential. Schools ought to assign different personnel for different stages of the procurement process. For example, invitation of suppliers for quotations/tenders; stores inspection and certification of services; certification of payment should be handled by different staff.

Principle of Fairness

9. All suppliers invited should be provided with **sufficient and equal**

knowledge of the quotation/tender requirements and specifications of the stores/equipment/services through the quotation/tender documents and, if necessary, oral briefings. No one should get more information or more notice about the quotation/tender. The specifications should be worded in easily comprehensible general terms based on the functional and performance characteristics of the stores and services required.

10. At least three weeks should be set between the issue and closing of a written quotation/tender. However, for urgent requirement, the written quotation/tender closing period may be shortened to two clear working weeks after obtaining approval from the Principal with the justifications recorded.

Security of Information

11. Quotation/tender information must be kept confidential with restricted access on a need-to-know basis. All communications regarding quotations/tenders must be classified as RESTRICTED DOCUMENTS from the time quotations/tenders are received and to the time a decision is made on the acceptance or otherwise of the quotation/tender.

12. **The requirement in paragraph 11 should be annually brought to the notice of the staff involved by means of a circular which they should be required to sign to indicate that they have read and understood it.** In addition, they should sign an undertaking that they would not make any unauthorised disclosure of quotation/tender information.

Procurement Procedures

13. The revised financial limits of procurement and their corresponding procurement arrangements and approving authorities are summarised below:

Financial limits	Procurement arrangements	Approving authorities
\$5,000 or below	Competitive bidding not required for procurement of any stores or services provided that a member of school staff at an appropriate level certifies that such procurement is essential and the prices are fair and reasonable	Principal/Deputy Head <i>[Note: For schools without Deputy Head, the approving authority rests with the Principal.]</i>
Above \$5,000 to \$50,000	By oral quotations (at least two)	
Above \$50,000 to \$200,000	By written quotations (at least five)	Principal
Above \$200,000	By tenders (at least five)	Tender Approving Committee comprising the School Supervisor/Manager,

Financial limits	Procurement arrangements	Approving authorities
		the Principal, a teacher and a representative of the Parent-Teacher Association or a parent manager

14. Schools may only make repeated procurement of the same items within 12 months by oral quotations and written quotations if the cumulative value of the procurement does not exceed \$50,000 and \$200,000 respectively. Schools must not split an order as a way to circumvent approval requirement or quotation/tendering procedures. Items of stores and services of the same category are to be grouped in the same quotation/tender schedule before inviting suppliers to bid. Schools should not evade the financial limits set out in paragraph 13 by dividing procurement requirements into instalments or by reducing the usual duration of contracts.

15. When inviting suppliers, the last successful supplier should always be invited to bid subject to satisfactory performance. For the remaining suppliers, schools may refer to the EDB Notification Lists or other possible sources of supply identified. Suppliers should be invited by rotation to ensure equity.

For procurement at an estimated cost of up to \$50,000 each

16. Procurement should be handled by school staff at an appropriate level. School staff should note that a single procurement is taken as a bill of procurement of relevant items from a single company on any one occasion.

17. Suppliers may be contacted by phone/fax to invite **oral quotations**. They should be advised of the deadlines (i.e. closing date and time of the oral quotations) and the mode of return (i.e. by telephone, by hand, by fax, etc.).

18. **If it is not possible to invite/receive the minimum number of oral quotations, an explanatory note should be made on the Purchase-by-Oral Quotation Form (see Annex II for reference), and it should be endorsed by the Panel Head of the subject or a staff member with the salary point not lower than Master Pay Scale Point 25.**

19. School staff at an appropriate level should complete the Purchase-by-Oral Quotation Form with recommendations and submit it with the quotations received, if any, to the Principal/Deputy Head for approval. Before making recommendations, due consideration should also be given to the comparison between the price and quality of the stores and services offered by the suppliers and those available on the market. If the lowest quotation is not selected, school staff should record the reason why it is not chosen. Schools should keep the Purchase-by-Oral Quotation Form and the quotations received, if any, for audit purpose for a period of three calendar years after the completion of the order.

20. On approval by the Principal/Deputy Head, schools can then place orders.

21. Supervisory checks should be conducted randomly to satisfy that the quotations obtained are genuine. Responsible staff should date and initial on the Purchase-by-Oral Quotation Form to show that the quotations have been checked.

For procurement at an estimated cost of more than \$50,000 each

22. **The procurement procedures of written quotations and tenders are basically the same except those as stated in paragraphs 30, 36, 37, 47 and 48.**

Preparation of written quotation/tender documents

23. To handle written quotation/tendering matters, schools should refer to the “Notes for Preparation of Invitation to Written Quotation/Tender” at **Annex III** with a sample of invitation letter and separate written quotation/tender forms for procurement of stores and services. All these documents are for general reference only. Each school should seek its own independent legal advice and, where necessary, advice from the school’s technical advisers, on the terms and conditions to be adopted in the invitation letters and written quotation/tender document for each written quotation/tender exercise. The Government of the Hong Kong Special Administrative Region and its public officers shall not be liable for any losses, damage and claims of any nature whatsoever that may arise from the school’s adopting any of the terms or conditions of the sample invitation letter and/or the written quotation/tender forms.

24. A copy of the written quotation/tender form should be provided for each supplier invited. The suppliers invited should be given full specifications of the required stores and services and, whenever possible, samples should be provided or shown to the suppliers so that they are certain of the type and finish of the item required, particularly where furniture is concerned. Schools should also spell out the pre-determined assessment criteria and marking scheme, if applicable, in the written quotation/tender documents for reference of the prospective bidders.

25. The closing date and time for submission of written quotations/tenders must be clearly specified in the written quotation/tender invitation documents.

Invitation of written quotation/tender

26. Schools should seek written quotations for single procurement above \$50,000 and up to \$200,000, and tenders for single procurement above \$200,000 from **at least five suppliers. If it has not been possible to invite sufficient number of suppliers, the circumstances should be explained and recorded on file. Prior approval should also be obtained from the SMCs/IMCs.**

27. Suppliers should be advised to return written quotations/tenders in duplicate under sealed envelopes marked “WRITTEN QUOTATIONS/TENDERS” with the written quotation/tender number and written quotation/tender closing date and time on the cover and addressed to the Principal by post title. It is advisable for schools to provide pre-addressed envelopes or envelope-covers to suppliers to avoid the omission of relevant data. Suppliers should be advised not to identify themselves on the written quotation/tender cover. Schools should indicate the names of suppliers who have been

invited on a Written Quotation/Tender Summary and Approval Record (see **Annex IV** for reference) which has to be passed to the written quotation/tender opening authority for recording the details of the responses.

28. All written quotation/tender documents should be sent to the selected suppliers by registered mail. Schools should maintain on file the recorded delivery receipts issued by the post office, showing the names of the suppliers and the date of despatch for audit purpose.

Submission of written quotation/tender

29. Suppliers should return written quotation/tender in duplicate to schools by mail or by hand. They should also be requested to return the written quotation/tender forms to the school stating “No Offer” even if they do not intend to submit any written quotation/tender.

30. **Written quotations must be locked up** and the key is to be kept by a member of school staff at an appropriate level whereas **tenders must be placed into the tender box** immediately upon receipt.

Tender Box

31. A tender box (see **Annex V** for reference) should be installed as a fixture in a permanent and convenient location in the General Office to ensure proper control over the receipt of tenders.

32. The tender box must be under double lock. The key to each lock must be held by different school staff, one of whom should be at a supervisory rank.

33. The tender box must be opened at a specific time according to school’s tender opening schedule. Tenders must be opened immediately if they bear a tender closing date and time which are the same as the date and time when the tender box is opened.

34. In case Tropical Cyclone Warning Signal No. 8 or above is hoisted, or Black Rainstorm Warning Signal or “extreme conditions” announced by the Government is/are in force on the tender closing date, the tender box should be opened on the next working day at the same time.

35. A spare set of keys is to be held by the Principal in case any key holders are unavailable when the tender box is due for opening.

Opening and vetting of written quotation/tender

36. For written quotations, **two staff members at an appropriate level** will be appointed by the Principal for opening, vetting and referring written quotation documents to the appropriate subject teacher(s) and administrative staff for evaluation and recommendation before referring the written quotation documents to the Principal for consideration and approval.

37. For tenders, a **Tender Opening and Vetting Committee (TOVC)** should be set up as follows:

- (a) The TOVC comprising two staff members (one with the salary point not lower than Master Pay Scale Point 25 and the other of a rank not lower than a Clerical Assistant or equivalent) will be appointed by the Principal **at least three working days** before the tender opening date. The two staff members of the TOVC should be appointed by rotation, whenever possible.
- (b) No forward roster of serving the TOVC needs to be maintained. A history of appointments shall, however, be maintained by the Principal in case it becomes necessary to check on the composition of a particular TOVC at a later date.
- (c) The TOVC is responsible for opening, vetting and referring tender documents to the appropriate subject teacher(s) and administrative staff for evaluation and recommendation before referring the tender documents to the Tender Approving Committee set out in paragraph 48 for consideration and approval.

38. The staff members assigned to open the written quotations are required to take action in line with the requirements set out in paragraph 39.

39. No tenders are to be opened before the tender closing date and time. The TOVC opens the tender box at the specified time on the closing day of the tender and identifies tenders due for closing on that day as well as late tenders for action. Tenders which bear a closing date later than the date of collection should be date-chopped and signed by all members of the TOVC, and then re-deposited into the tender box until this box is re-opened. The TOVC must ensure that the tender box is locked and return keys to the key holders. Once date-chopped, second date-chopping on these tender covers by subsequent TOVC is not necessary.

40. All written quotations/tenders should be sorted by the written quotation/tender opening authority in a locked-up room. In the event that the opening of written quotations/tenders for the day cannot be completed within the school hours, the written quotation/tender opening authority shall secure the written quotations/tenders in a safe place inside the locked-up room and continue the opening of written quotations/tenders the following day. The key of the room should be kept by the Principal.

41. If written quotation/tender covers are received without a closing date and time, the written quotation/tender opening authority will still open the written quotations/tenders and action will be taken in line with paragraphs 38 to 40 and 42 to 46 **as appropriate**. Written Quotation/Tender covers without closing dates but with other identifiable features (e.g. written quotation/tender title or written quotation/tender reference number) should not be opened until the written quotation/tender closing date.

42. Late written quotations/tenders should not be opened and their covers should

be clearly marked “LATE WRITTEN QUOTATION/TENDER, RECEIVED BY THE WRITTEN QUOTATION/TENDER OPENING AUTHORITY ON _____” and initialed by all members of the written quotation/tender opening authority before referring them to the written quotation/tender approving authority to decide on their validity. In principle, late written quotations/tenders should not be considered unless only one supplier has been invited. Late written quotations/tenders which the approving authority does not want to consider further should be returned under a covering letter to the suppliers. Special attention is to be paid to fairness to other suppliers in case a late written quotation/tender is to be validated.

43. On opening written quotations/tenders, the written quotation/tender opening authority should initial, date-stamp and check all written quotations/tenders to see if both the original and duplicate copies of the written quotations/tenders are identical. If alterations/amendments are found on a written quotation/tender document, the written quotation/tender opening authority should ensure that the alterations/amendments on the original copy and the duplicate are identical and then circle the revised amount/rate in red on both copies as well as initial against the revised amount/rate.

44. The written quotation/tender opening authority should enter relevant information of all written quotations/tenders received in the Written Quotation/Tender Summary and Approval Record (see **Annex IV** for reference). Random enquiries should be made to find out and record the reasons for unreturned written quotations/tenders (e.g. lost in mail).

45. Only the original set of written quotations/tenders should be passed to the subject teacher(s)/administrative staff to make recommendations. The duplicate set should be kept separately under lock and key for checking against the original set if alteration of written quotations/tenders is suspected. Before making recommendations, due consideration should also be given to the comparison between the price and quality of the stores and services offered by the suppliers and those available on the market.

46. After vetting the written quotation/tender documents, requesting the subject teacher(s)/administrative staff to make recommendations on the written quotation/tender and completing the relevant parts of the Written Quotation/Tender Summary and Approval Record, the written quotation/tender opening authority will then pass this record and the written quotation/tender documents to the approving authority for consideration and approval.

Approval of written quotation/tender

47. For written quotations, the approving authority rests with the **Principal**.

48. For tenders, a **Tender Approving Committee (TAC)** comprising the School Supervisor/Manager, the Principal, a teacher and a representative of the Parent-Teacher Association or a parent manager should be set up. Members of the TAC are to be appointed by the SMC or IMC. The TOVC and the TAC must be made up of different staff members and the subject teacher(s)/administrative staff responsible for making recommendations are to be excluded.

49. Before considering the recommendations, the written quotation/tender approving authority should randomly check the originals against the duplicates to ascertain that they have not been tampered with.
50. Normally, the lowest offer to specifications should be selected. If this is not the case, reasons for rejecting the lower offers should be provided. If a marking scheme is adopted, normally the written quotation/tender attained with the highest overall score should be recommended for acceptance.
51. If written quotation/tender documents are not in order (e.g. no offer complies with written quotation/tender specifications; price unreasonably high; terms unacceptable such as demand for pre-payment), the written quotation/tender approving authority may give instruction to re-invite written quotation/re-tender with revised specifications, terms and conditions, where applicable.
52. After ensuring availability of funds, the written quotation/tender approving authority may then approve the recommended written quotation/tender. Unsuccessful suppliers may be informed of the outcome after the contract has been awarded.
53. Schools should place orders before the expiry of the written quotation/tender validity period.
54. Schools should retain all original written quotations/tenders submitted by the suppliers and written quotation/tender documents including the Written Quotation/Tender Summary and Approval Record for audit purpose for a period of three calendar years after the completion of the order.

Single Quotation/Tendering

55. Procurement of stores and services should be made through competitive bidding as far as possible. **Schools should note that single quotation/tendering should be fully justified and used only in circumstances when competitive bidding would not be an effective means of obtaining the requisite stores and services, for instance:**
- (a) where there is evidently only one potential supplier capable of providing the requisite stores and services;
 - (b) where for reasons connected with the protection of copyrights or technical reasons;
 - (c) where services are to be provided by utility companies; or
 - (d) where maintenance is to be executed on patent or specialized equipment and where the warranty of the equipment gives the supplier of the equipment the exclusive right to carry out the maintenance service.
56. Single quotation/tendering procedures could only be initiated with the prior

approval from relevant authority set out as follows and with the decisions together with justifications be properly documented:

- (a) For procurement at an estimated cost of up to \$50,000 each, prior approval has to be obtained from the Panel Head of the subject or a staff member with the salary point not lower than Master Pay Scale Point 25.
- (b) For procurement at an estimated cost of more than \$50,000 each, prior approval has to be obtained from the SMCs/IMCs.

57. Schools should follow the same procurement procedures applicable to competitive bidding for quotation/tender.

Involvement of School Sponsoring Bodies (SSBs) in Schools' Procurement Activities

Acquiring stores and services through SSBs

58. When SSBs are delegated by the SMCs/IMCs to carry out procurement activities on behalf of the schools, SSBs are required to follow the same procurement procedures as the aided schools.

59. Before delegations take place, **prior approval must be obtained from the SMCs/IMCs** and such records should be properly documented.

60. All relevant procurement records (including the invoices and payment vouchers, if any) should be made available to schools for audit purpose. The SMCs/IMCs have the obligation to ensure SSBs' compliance with the procurement requirements set out in this set of Guidelines.

Acquiring stores and services from SSBs

61. If SSBs wish to provide stores and services to their schools, they should be treated as one of the bidders and subject to competitive bidding and the same selection procedures applicable to other bidders.

62. The SMCs/IMCs should ensure that the SSBs concerned are treated equally and fairly as other bidders. Special attention is drawn to declaration of conflict of interest as set out in paragraph 7.

Acquiring stores and services from SSBs by single quotation/tendering

63. Schools must observe the requirements as set out in paragraph 55 and **prior approval must be obtained from the SMCs/IMCs**.

64. To enable SMCs/IMCs to determine whether to accept the offer of SSBs or not, SSBs should submit price quotation with cost breakdown for the stores and services. After vetting the quotation/tender offered by the SSBs, **the accepting authority rests with the SMCs/IMCs**. The decision of the SMCs/IMCs together with

the grounds leading to the decision should be properly documented.

65. In handling the single quotation/tender submitted by the SSBs, SMCs/IMCs should refer to the “Checklist for Issue and Vetting of Single Quotation/Tender for Supplies of Stores and Services by School Sponsoring Body” at **Annex VI**.

Sub-contracting

66. To ensure quality of services, schools are not advised to accept contractor sub-contracting service/procurement to a third party. If considered appropriate, schools may set out the following in their quotation/tender invitation:

- (a) The contractor shall not sub-contract, assign or otherwise transfer or dispose of the contract or any part thereof or any rights and obligations without the prior written consent of the SMCs/IMCs.
- (b) The contractor shall not, without the prior written consent of the SMCs/IMCs, enter into any sub-contract with any person for the performance of any part of the contract. If the contractor considers it necessary to sub-contract the work/services, the contractor shall submit the proposed sub-contract to the SMCs/IMCs for approval. The SMCs/IMCs reserve the right to grant permission for sub-contracting and determine the terms and conditions of the sub-contract.
- (c) The contractor shall remain fully liable and shall not be relieved from any of its relevant obligations by entering into any sub-contract for the performance of any part of the contract and the contractor shall be responsible for the acts, defaults or neglect of any sub-contractor, its employees and agents.

Services from Social Enterprises

67. It is the Government’s objective to enable people with disabilities (PWDs) to integrate into the community through the process of vocational rehabilitation and eventual gainful employment. While not affecting the quality of services provided to the students at large and with the prior approval from their SMCs or IMCs, schools are encouraged to procure services provided by social enterprises set up by non-governmental organisations (NGOs) which employ PWDs when opportunities arise to promote self-reliance and employment opportunities for PWDs. These organisations create training and work opportunities for PWDs and run diversified business which includes services on a longer-term (such as cleaning service, repair and maintenance, transportation service, tuck-shops in schools) as well as services on a one-off basis (such as catering services for school functions, painting, non-structural renovation works). The services provided by these disabled people to schools would also help heighten students’ awareness of the diversity of our society and promote social harmony.

68. For details of services provided by social enterprises set up by NGOs which employ PWDs, schools may visit the website of the Marketing Consultancy Office (Rehabilitation) of the Social Welfare Department at <http://www.mcor.swd.gov.hk> or

the Social Enterprise Resource Web at <http://www.socialenterprise.org.hk>. Schools may also contact the Marketing Consultancy Office (Rehabilitation) direct at 3586 3446.

Supplies Inspection Team

69. The EDB will conduct inspections to schools to ensure compliance with the procurement procedures as laid down in this set of Guidelines and to advise on supplies management and inventory control.

Other Useful References

70. For more details of the procurement procedures and the handling of government subventions, schools may refer to the “Tips on Handling Government Subventions for Aided Schools” available on the EDB homepage [<http://www.edb.gov.hk/en/index.html> (*EDB homepage → School Administration and Management → Financial Management → Information on Subsidy → Reference Materials on Handling Government Subventions for Aided Schools*)]. Other useful information can also be found in “Best Practice Checklist on Governance and Internal Control in Schools” published by ICAC, which is available on ICAC Corruption Prevention Advisory Service homepage [<https://cpas.icac.hk/> (*CPAS homepage → Guides and Tools → Education*)].

71. The Government has implemented new measures to enhance the protection and benefits of non-skilled workers employed under government service contracts. Aided schools are encouraged to adopt them as far as practicable. For more details, schools may refer to “Arrangement Relating to the Employment of Non-Skilled Workers Under Government Service Contracts” at **Annex VII**.

Summary Workflow of Procurement Procedures in Aided Schools (Estimated Cost of up to \$50,000 each)

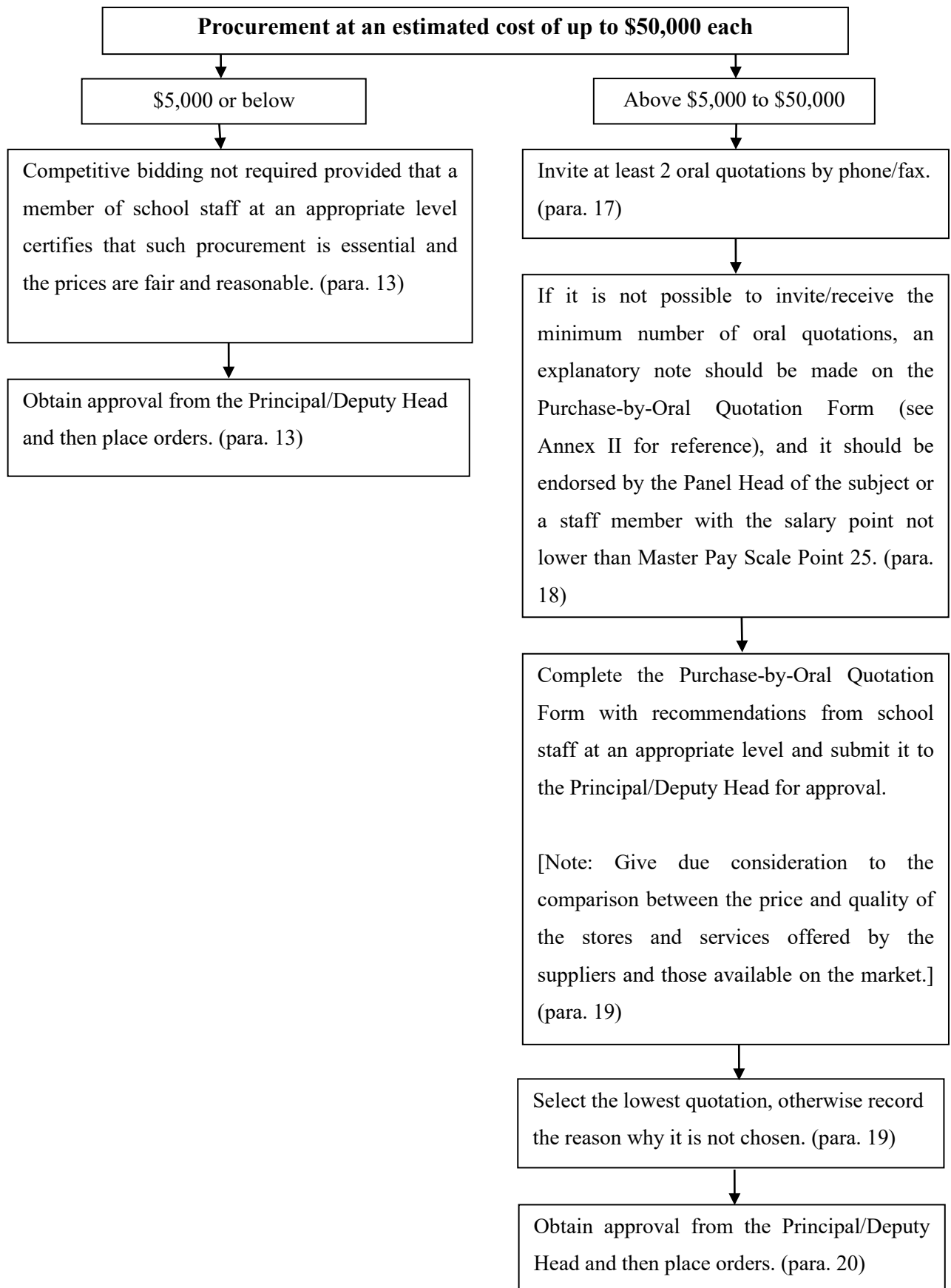

Summary Workflow of Procurement Procedures in Aided Schools (Estimated Cost of more than \$50,000 each)

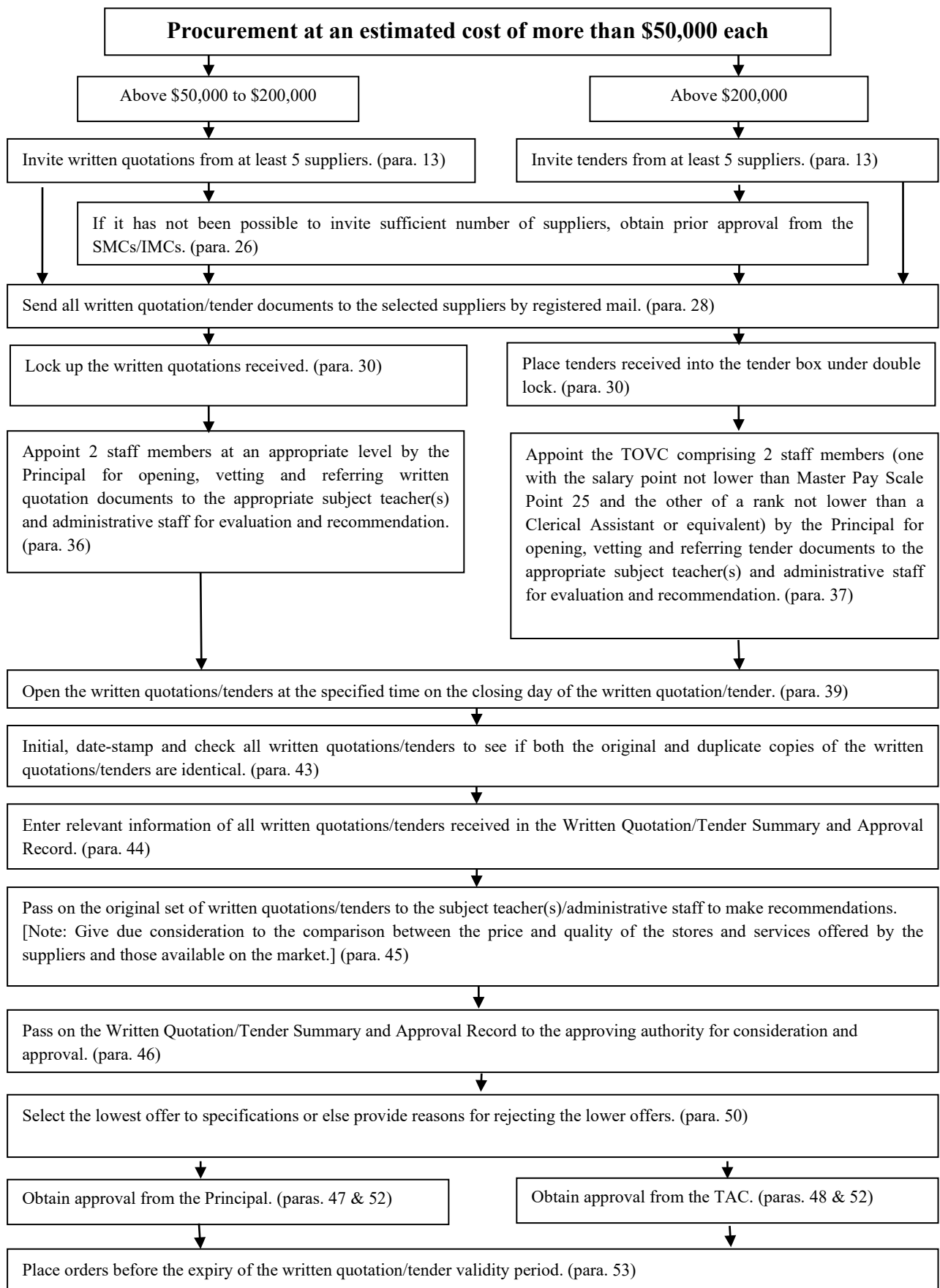

(for school’s reference only)

Sample Form for Declaration of Conflict of Interest

Part A – Declaration of Interest ¹

To: *School Management Committee/Incorporated Management Committee

I understand that if I have any direct or indirect interest in any *person/company which has official dealings with the school, I shall make a declaration to the *School Management Committee/Incorporated Management Committee.

I would like to declare the following *existing/potential conflict of interest situation arising from the discharge of my duties concerning the procurement of stores and services of the school:-

a) *Persons/companies with *whom/which I have official dealings *and/or private interests:

b) Brief description of my duties which involve the *persons/companies mentioned in item (a) above:

Signature: _____

Name and Position: _____

Date: _____

Part B – Record of Resolution of the School Management Committee/Incorporated Management Committee

With respect to the above declaration,

- (name of the person making the declaration) should refrain from performing or getting involved in performing the *work/duty, as described in Part A, which may give rise to a conflict.
- (name of the person making the declaration) may continue to handle the *work/duty as described in Part A, provided that there is no change in the information declared above.
- Others (please specify)

Signature: _____

Name of Supervisor ²: _____

Date: _____

(*Delete as appropriate)

¹ In the daily operation, as circumstances or events warrant, the persons concerned should draw management authority’s attention to his/her perceived conflict of interest. When such a situation arises, the School Management Committee (SMC) / Incorporated Management Committee (IMC), or the school principal as appropriate, should decide whether the person disclosing an interest shall be required to abstain from the duty assigned, or to abstain from the deliberation and decision on the subject.

² For declarations made by school staff (excluding school principal) in respect of procurement of stores and services, the SMC/IMC may delegate the approving authority to the school principal.

(for school's reference only)

School Ref.:

To : * Principal/Deputy Head

Purchase-by-Oral Quotation Form

I have invited the following oral quotations (above \$5,000 to \$50,000) for supply of stores or services. After comparing the price and quality of the stores or services offered by the suppliers and those available on the market, I wish to recommend acceptance of the * lower/higher offer from _____. The reasons for not accepting the lowest offer are as follows : _____

Item No.	Brief Description of Item	Quantity Required	Name and Phone Number of Supplier	Unit Price	Total Amount	Offer Accepted "✓"
			(1)			
			(2)			

If less than two quotations are invited/received, please provide reasons in the box below :

Less than two quotations are invited/received because _____ Endorsed by : _____ (Rank _____ / Post _____)

As the item is required by _____, I have requested the supplier to deliver the item on or before _____, if approved. Payment may be effected after satisfactory receipt of the stores on _____.

I confirm that the above item is a single procurement and not part of a large consignment to be procured by instalments.

Quotation invited by : _____ Signature : _____
 Rank : _____ Date : _____

- * I certify that the oral quotation procedures are in order and approve the above recommendation; or
- * I consider that re-inviting the oral quotation is required; or
- * I disapprove the recommendation because _____

Signature of :

_____ * Principal/Deputy Head

Date :

*Please delete as appropriate

(for school's reference only)

Notes for Preparation of Invitation to Written Quotation/Tender

Notes for Preparation of Invitation to Written Quotation (above \$50,000 to \$200,000)/Tender (above \$200,000) Letter (Annex III a)

- Firm Name and Address - As indicated in the EDB Notification Lists, etc.
- School Ref. No. - According to the school's filing series.
- Date - The date of mailing of invitation despatched by Registered Mail.
- Para. 2 - Indicate the category of stores to be supplied or the services to be undertaken.
- e.g. (i) "Written Quotation/Tender for the supply of scientific equipment"
- (ii) "Written Quotation/Tender for the service of repair of school furniture"

DO NOT USE ONE INVITATION FOR TWO CATEGORIES OF STORES INVOLVED.

..... addressed to the Principal, and full postal address of the school

..... "noon on (date)" refers to the written quotation/tender closing date which has been set. Capital letters be printed, e.g. 23 APRIL 2013.

It is preferable to set the closing date on Monday because there will be four and a half consecutive

working days for completion of the Written Quotation/Tender Summary and Approval Record at **Annex IV**. At least three weeks should be given to suppliers before written quotation/tender closes.

Notes for Preparation of Written Quotation/Tender Schedule (attached at **Annex III a**)

The school may use large sheets or continuation sheets with page number inserted at the right hand corner on the top but the format should be the same as illustrated.

Wider spacing should be provided between the items.

Notes for Preparation of Written Quotation/Tender Form for Stores (**Annex III b**)

- The heading - Written Quotation/Tender form for the supply of
(Insert the category of stores required.)
- School Ref. No.)- Identical to those as specified in the
Written Quotation/Tender Closing date) written quotation/tender invitation.
and time)

- PART II - To be examined by the school and to ensure that this part is completed by the supplier.

Notes for Preparation of Written Quotation/Tender Form for Services (**Annex III c**)

Same application as above except the category of services to be provided should be inserted in the heading.

e.g. FOR THE SERVICE OF REPAIRING FURNITURE

(for school's reference only)

Invitation to Written Quotation/Tender Letter

(Suppliers should be reminded not to identify their companies on the envelopes)

School Ref. No.

Date

Firm name
and address

By Registered Mail

Dear Sirs,

INVITATION TO WRITTEN QUOTATION/TENDER
WRITTEN QUOTATION/TENDER FOR THE SUPPLY OF
(Specify the category of stores or services)

You are invited to quote/tender for the supply of the stores or services as specified in the enclosed written quotation/tender schedule. If you are not prepared to accept a partial order, please state this clearly on the written quotation/tender schedule.

2. Your sealed written quotation/tender, in duplicate, should be clearly marked on the envelope:

Written Quotation/Tender for _____

The envelope should be addressed to _____
_____ and arrive not later than 12:00 noon on (date) _____.

Late written quotations/tenders will not be accepted. Your written quotation/tender will remain open for 90 days from the "Closing Date", and you may consider your written quotation/tender to be unsuccessful if no order is placed with you within these 90 days. You are requested to note that unless Part II of the written quotation/tender form is completed, the written quotation/tender will not be considered.

3. If you are unable or do not wish to quote/tender, it would be appreciated if you return the written quotation/tender form with reason to the above address at your earliest convenience.

4. Written Quotations/Tenders will be accepted on an * 'overall'/ 'group'/ 'itemised' basis.

Yours sincerely,

()

* Please delete as appropriate

**Written Quotation/Tender Schedule
(to be completed in duplicate)**

(Columns 4, 5 and 6 to be completed by Supplier)

(1) Item No.	(2) Description/Specification	(3) Quantity Required	(4) Unit Rate (HK\$)	(5) Total Amount (HK\$)	(6) Delivery Offered
	<u>Delivery required</u>				

We/I understand that if we/I fail to supply the stores or services as offered in our/my written quotation/tender upon accepting school's order, we are/I am prepared to pay the price difference to the school if such stores or services are obtained from elsewhere.

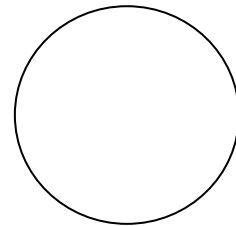

Company Chop

Name of Supplier: _____

Name and Signature of Person authorized to sign Written Quotation/Tender

Name (in block letters): _____ Signature: _____

Date: _____

(for school's reference only)

Written Quotation/Tender Form for Stores

WRITTEN QUOTATION/TENDER FORM FOR THE SUPPLY OF
(Specify the category of stores)

Name and Address of School: _____

School Ref. No. (to be entered by school): _____

Written Quotation/Tender Closing Date and Time (to be entered by school): _____

PART I

The undersigned hereby offers to supply all or any part of the items described in the written quotation/tender schedule attached with the delivery term quoted therein against the date of a firm order placed by the school at the price or the prices quoted in the written quotation/tender schedule free of all other charges and in accordance with any drawings and/or specifications provided by the school. In so doing, the undersigned acknowledges that all items not otherwise specified shall be in accordance with British Standard specifications where such exist; written quotations/tenders shall REMAIN OPEN FOR 90 DAYS after the Closing Date; and the school is not bound to accept the lowest or any written quotation/tender and reserves the right to accept all or any part of any written quotation/tender within the period during which the written quotation/tender remains open. The undersigned also warrants that his Company's Business Registration and Employees' Compensation Insurance Policy are currently in force and that the items which his Company offers to supply do not to his knowledge infringe any patents.

PART II

RECONFIRMATION OF WRITTEN QUOTATION/TENDER VALIDITY

With reference to Part I of this written quotation/tender form, it is reconfirmed that the validity of written quotation/tender offered by this company remains open for 90 days from _____.

The undersigned also agrees to accept the fact that once the validity of written quotation/tender is reconfirmed, the pre-printed clause specified in the Company's written quotation/tender forms in regard to this nature shall NOT apply.

PART III

SAFEGUARDING NATIONAL SECURITY

The undersigned acknowledges that notwithstanding anything to the contrary in the quotation/tender documents, the school reserves the right to disqualify this company on the grounds that this company has engaged, is engaging, or is reasonably believed to have engaged or be engaging in acts or activities that are likely to cause or constitute the occurrence of offences endangering national security or otherwise the exclusion is necessary in the interest of national security, or is necessary to protect the public interest of Hong Kong, public morals, public order or public safety.

The undersigned also acknowledges that the school may immediately terminate the contract upon the occurrence of any of the following events:

- (a) this company has engaged or is engaging in acts or activities that are likely to cause or constitute the occurrence of offences endangering national security or which would otherwise be contrary to the interest of national security;
- (b) the continued engagement of this company or the continued performance of the contract is contrary to the interest of national security; or
- (c) the school reasonably believes that any of the events mentioned above is about to occur.

Dated this _____ day of _____ 20_____.

Name (in block letters) : _____

Signature : _____ in the capacity of _____
(state official position e.g. Director, Manager, Secretary)

Duly authorized to sign written quotations/tenders for and on behalf of : -

whose registered office is situated at _____

_____ Hong Kong.

Telephone No. : _____

Fax No. : _____

(updated in June 2023)

Annex III c

(for school's reference only)

Written Quotation/Tender Form for Services

WRITTEN QUOTATION/TENDER FORM FOR THE SERVICE OF
(Specify the category of services)

Name and Address of School: _____

School Ref. No. (to be entered by school): _____

Written Quotation/Tender Closing Date and Time (to be entered by school): _____

PART I

The undersigned hereby offers to undertake the service as described in the written quotation/tender schedule within the period of time as specified therein from the date of a firm order placed by the school at the price or prices quoted in the written quotation/tender schedule including labour, materials, all other charges and in accordance with the details provided by the school. In so doing, the undersigned acknowledges that all items not otherwise specified shall be provided in accordance with such details; written quotations/tenders shall REMAIN OPEN FOR 90 DAYS after the Closing Date; and the school is not bound to accept the lowest or any written quotation/tender and reserves the right to accept all or any part of any written quotation/tender within the period during which the written quotations/tenders remain open. The undersigned also warrants that his Company's Business Registration and Employees' Compensation Insurance Policy are currently in force and that the service which his Company offers to undertake will not cause any damage to the school's premises.

PART II

RECONFIRMATION OF WRITTEN QUOTATION/TENDER VALIDITY

With reference to Part I of this written quotation/tender form, it is reconfirmed that the validity of written quotation/tender offered by this company remains open for 90 days from _____.

The undersigned also agrees to accept the fact that once the validity of written quotation/tender is reconfirmed, the pre-printed clause specified in the Company's written quotation/tender forms in regard to this nature shall NOT apply.

PART III

SAFEGUARDING NATIONAL SECURITY

The undersigned acknowledges that notwithstanding anything to the contrary in the quotation/tender documents, the school reserves the right to disqualify this company on the grounds that this company has engaged, is engaging, or is reasonably believed to have engaged or be engaging in acts or activities that are likely to cause or constitute the occurrence of offences endangering national security or otherwise the exclusion is necessary in the interest of national security, or is necessary to protect the public interest of Hong Kong, public morals, public order or public safety.

The undersigned also acknowledges that the school may immediately terminate the contract upon the occurrence of any of the following events:

- (a) this company has engaged or is engaging in acts or activities that are likely to cause or constitute the occurrence of offences endangering national security or which would otherwise be contrary to the interest of national security;
- (b) the continued engagement of this company or the continued performance of the contract is contrary to the interest of national security; or
- (c) the school reasonably believes that any of the events mentioned above is about to occur.

Dated this _____ day of _____ 20_____.

Name (in block letters) : _____

Signature : _____ in the capacity of _____
(state official position e.g. Director, Manager, Secretary)

Duly authorised to sign written quotations/tenders for and on behalf of : -

whose registered office is situated at _____

_____ Hong Kong.

Telephone No. : _____

Fax No. : _____

(for school's reference only)

**Written Quotation/Tender Summary and Approval Record of
Written Quotation/Tender No. _____
for the supply of _____ (Stores or Services)**

Name of School : _____

School Written Quotation/Tender Reference : _____

Date of Issue : _____ Date of Closing : _____

Date of Approval : _____

Validity of Written Quotation/Tender up to : _____

Supplier's Name	Offer	No Offer	Received Late	No Reply	Brief Description of Item				Recommendation
					Quantity Required				
					Total Cost				

<p>We certify that we have date-stamped, initialed on and vetted every written quotation/tender</p>	<p>For written quotation Signature of teacher/administrative staff: _____ Name (in Block Letter): _____</p> <p>Signature of teacher/administrative staff: _____ Name (in Block Letter): _____</p> <p>For tender Signature of TOVC Chairperson: _____ Name (in Block Letter): _____</p> <p>Signature of TOVC Member: _____ Name (in Block Letter): _____</p>
---	---

<p>I recommend the written quotation/tender as indicated above</p>	<p>Signature of teacher/administrative staff: _____ Name (in Block Letter): _____</p>
<p>* I/We certify that the written quotation/tender vetting procedures are in order and approve the above recommendation OR * I/We consider that re-inviting written quotation /re-tendering is required OR * I/We disapprove the recommendation because _____ _____ *Please delete as appropriate</p>	<p>For written quotation Signature of Principal: _____ Name (in Block Letter): _____</p> <p>For tender Signature of TAC Chairperson: _____ Name (in Block Letter): _____</p> <p>Signature of TAC Member: _____ Name (in Block Letter): _____</p> <p>Signature of TAC Member: _____ Name (in Block Letter): _____</p> <p>Signature of TAC Member: _____ Name (in Block Letter): _____</p>

(for school's reference only)

Tender Box Design

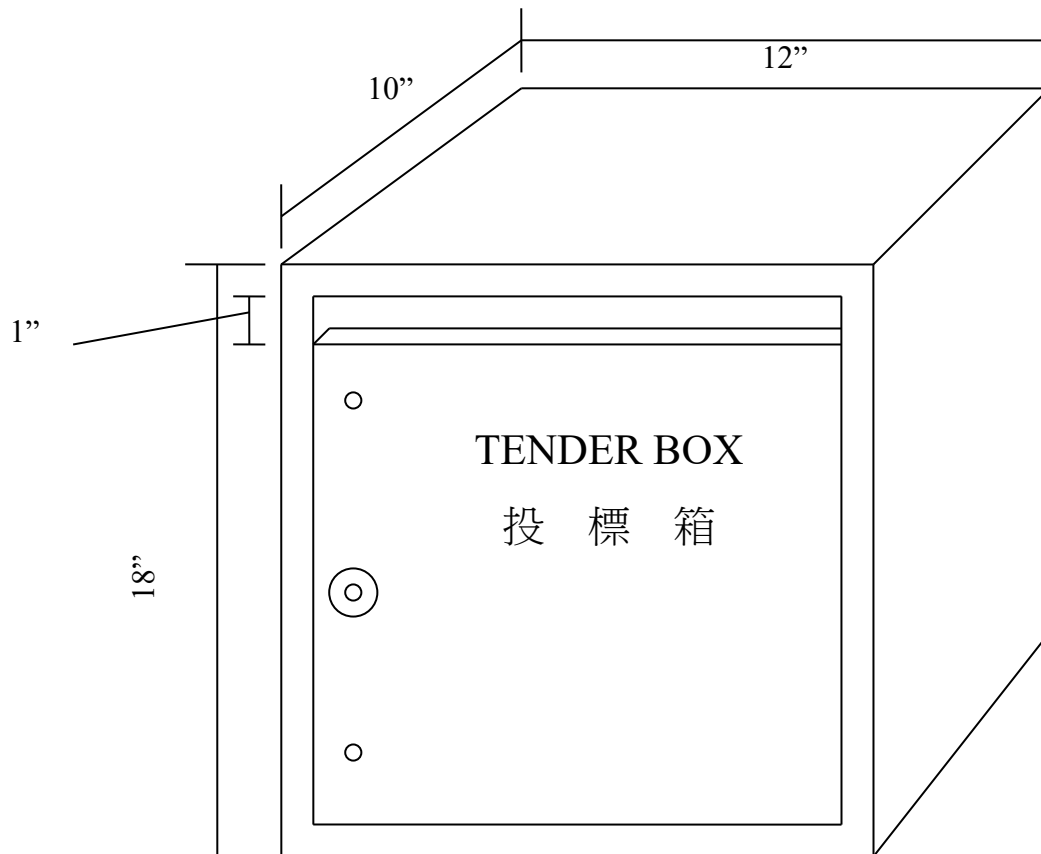

Size 12" (W) 18" (H) 10" (D) with an opening of 1" x 12" at the front.

Material plywood of 5/8" thick.

Design 2 locks and a concave door handle with wordings of "Tender Box".

Checklist for Issue and Vetting of Single Quotation/Tender for Supplies of Stores and Services by School Sponsoring Body (SSB)

1. Issue of single quotation/tender		
1.1	Is the procurement by single quotation/tender fully justified? Single quotation/tendering procedures should be used only when open competitive quotation/tender exercise would not be an effective means of obtaining the requisite supplies or services.	Yes/No
1.2	Whether prior approval has been sought from SMC/IMC to adopt single quotation/tendering procedures? The following information should be provided to SMC/IMC for consideration when seeking their approval – (a) describe the stores and services to be procured; (b) state the estimated cost; and (c) explain why single quotation/tender is invited.	Yes/No
1.3	Have officers involved in preparing quotation/tender documents and assessing quotations/tenders declared their interest according to paragraph 7 of the Guidelines?	Yes/No
1.4	Whether the justifications and SMC/IMC's approval for adopting single quotation/tendering procedures have been properly recorded for audit purpose?	Yes/No
1.5	Has the SSB (being invited to submit quotation/tender under the single quotation/tendering arrangement) submitted quotation/tender in the same manner as stipulated in paragraphs 29 to 35 of the Guidelines?	Yes/No
2. Vetting of quotation/tender received from SSB		
2.1	Has the quotation/tender been opened and vetted by the school's quotation/tender opening and vetting authority in accordance with paragraphs 36 to 46 of the Guidelines?	Yes/No
2.2	Whether breakdown of the quoted/tendered price by types of stores and services and by major components or items has been given by the SSB? (Suggested templates for breakdown of the quotation/tender price for provision of management and financial services, information systems and training services are at Annexes VI a, b and c for	Yes/No

	reference).	
2.3	<p>Whether the price of the quotation/tender offer is considered fair and reasonable by SMC/IMC? In doing so, SMC/IMC should substantiate its conclusion by –</p> <p>(a) comparing the offer of SSB against the quotation/tender documents to ensure that the offer of SSB conforms with the specifications and terms and conditions laid down in the quotation/tender documents;</p> <p>(b) comparing the quoted/tendered price and the relevant cost breakdown against the market price of the same or similar products or services, if available, to see that they are comparable; and</p> <p>(c) comparing the quoted/tendered price against the estimated cost submitted to SMC/IMC for consideration when seeking its approval for adopting single quotation/tendering procedures, to ensure that they are comparable.</p> <p><u>Remark:</u> If the answer to this question is “No” (i.e. the quotation/tender received does not comply with the specifications, price unreasonably high or not comparable to market price, terms unacceptable), schools should consider to cancel the quotation/tender exercise and re-invite quotation/re-tender with revised specifications, terms and conditions. Where applicable, open competitive quotation/tender exercise should be considered.</p>	Yes/No
2.4	When price negotiation is required, has the school drawn up a negotiation brief setting out the directions and targets to be achieved as well as the baseline for negotiation? If yes, has prior agreement of SMC/IMC been obtained on the negotiation brief?	Yes/No
2.5	Whether the SMC/IMC’s assessment on and acceptance of the quotation/tender offered by the SSB have been properly recorded for audit purpose?	Yes/No

**Template for Breakdown of Quotation/Tender Price for
Provision of Management and Financial Services ^(Note)**

Item	Daily Rate \$	No. of Man-days	Total Amount \$
(A) Services A (e.g. Review of Accounting System)			
1) Staff Costs - Senior Professional/Senior Manager - Professional/Manager - Administrative Assistant - Others (please specify)			
2) Reimbursement Charges - Travelling - Photocopying - Others (please specify)			
3) Other costs (please specify)			
Total			
(B) Services B (e.g. Legal Charge for Incorporation)			
1) Staff Costs - Senior Professional/Senior Manager - Professional/Manager - Administrative Assistant - Others (please specify)			
2) Reimbursement Charges - Travelling - Photocopying - Others (please specify)			
3) Other costs (please specify)			
Total			

Note: If the total cost to be incurred by SSB is shared by a number of schools under the same SSB, SSB is required to provide the information on the apportionment basis (e.g. based on the number of classes/students of the respective schools) and the sharing percentage of individual schools as well. The sum of the sharing percentages for the schools concerned should not exceed 100%.

**Template for Breakdown of Quotation/Tender Price for
Provision of Information Systems ^(Note)**

(A) Hardware					
Name of System/Features	Description	Model No.	Quantity	Unit Rate \$	Total Amount \$
Sub-total					
(B) Software					
Name of System/Features	Description	Model No.	Quantity	Unit Rate \$	Total Amount \$
Sub-total					
(C) Development Cost					
Item			Daily Rate \$	No. of Man-days	Total Amount \$
1) Staff costs					
- Senior Consultant/Senior Manager					
- Consultant/Manager					
- System Analyst					
- Programmer					
- Others (please specify)					
2) Other costs (please specify)					
Sub-total					
(D) On-going Maintenance and Support					
Item	Description				Total Amount \$
Hardware	Annual Maintenance Charge				
Software	Annual Licence Fee				
	Annual Maintenance Charge				
Sub-total					
Grand Total (A + B + C + D)					

Note: If the total cost to be incurred by SSB is shared by a number of schools under the same SSB, SSB is required to provide the information on the apportionment basis (e.g. based on the number of classes/students of the respective schools) and the sharing percentage of individual schools as well. The sum of the sharing percentages for the schools concerned should not exceed 100%.

**Template for Breakdown of Quotation/Tender Price for
Provision of Training Services ^(Note)**

Item	Price \$	No. of classes offered	Total Amount \$
(A) Cost for one class for subject A - training staff cost - training material cost - other overhead (please specify)			
Sub-total			
(B) Cost for one class for subject B - training staff cost - training material cost - other overhead (please specify)			
Sub-total			
Total (A+ B)			

Note: If the total cost to be incurred by SSB is shared by a number of schools under the same SSB, SSB is required to provide the information on the apportionment basis (e.g. based on the number of classes/students of the respective schools) and the sharing percentage of individual schools as well. The sum of the sharing percentages for the schools concerned should not exceed 100%.

(updated in November 2024)

Annex VII

Arrangement Relating to the Employment of Non-Skilled Workers Under Government Service Contracts

Subsequent to the package of improvement measures introduced by the Government on 1 April 2019 to enhance the labour benefits of relevant non-skilled workers under government service contracts, the Chief Executive announced in his 2022 Policy Address that the Government would further review the arrangement relating to the employment of non-skilled workers under government service contracts, including remuneration of the workers, as well as the relevant monitoring mechanism.

2. A review has been completed by the Financial Services and Treasury Bureau, the Labour and Welfare Bureau and relevant departments. The **key findings and new measures** were reported to the joint meeting of Panel on Financial Affairs and Panel on Manpower of the Legislative Council in May 2023³.

3. The Government has led by example in enhancing the protection of the labour benefits of non-skilled workers employed under the government outsourced contracts. We encourage aided primary and secondary schools to **adopt the new measures as far as practicable**. The new measures are summarised as follows –

Enhancement measures

Enhancement in gratuity entitlement

4. Non-skilled workers with less than one year of continuous service with the government service contractors (GSCs), provided that the employment contracts have been terminated because the service requirements procured by the

³ Discussion Paper: <https://www.legco.gov.hk/yr2023/english/panels/fa/papers/famp20230508cb1-426-1-e.pdf>

Government are no longer necessary or because of the unsatisfactory performance of the contractor, would be entitled to gratuity payment at 6% of the total wages earned (whereas under the prevailing arrangement, non-skilled workers whose employment contracts end within one year after commencement, they are not entitled to gratuity payment). Besides, supervisory staff directly monitors the delivery of services by non-skilled workers, and plays a key role in ensuring the effective implementation of public services by the GSCs, entitlement for gratuity has also been extended to the supervisory staff of non-skilled workers.

Enhancing technical assessment of measures on improvement to environmental protection, social responsibility and governance

5. To make the government procurement regime more conducive to environmental protection, social responsibility or governance (ESG), at least 5% weighting would be assigned to ESG proposals (notably the employment of people with disabilities and/or rehabilitated persons) from the existing 20% weighting for innovative suggestions under the technical assessments. Accordingly, at least 15% weighting from the technical assessments would be assigned for innovative suggestions that adopt proposals on technological means/ arrangements/ work process/ solutions/ equipment to enhance efficiency, effectiveness and productivity of the service outcome of which the contributions should be visible and preferably be quantifiable and measurable.

Enhancing protection of occupational safety and health

6. To safeguard the occupational safety and health of non-skilled workers, it is an essential requirement that all tenderers must submit a Heat Stroke Prevention Work Plan in bidding government service contracts that involve non-skilled workers performing duties outdoors, in indoor work environment without air-conditioning and/or in the vicinity of heat sources. The Demerit Point System under the government procurement regime has also been expanded to cover non-compliances with the Heat Stroke Prevention Work Plan to ensure that the said Work Plan will be effectively implemented. Besides, a mandatory assessment of the adverse record of the tenderer in respect of the demerit point(s) accrued in the past three years has been included in the tender assessment process.

Strengthening monitoring framework

7. To strengthen the control and monitoring of the employment of non-skilled worker under government service contracts, a more standardised and consistent approach has been introduced for Bureaux/Departments to achieve two objectives, namely (a) service outcome monitoring to ensure our public service is delivered effectively in meeting the service standards and requirements of the relevant service contracts; and (b) labour protection to ensure that measures to protect non-skilled workers' wages and other labour benefits are properly implemented by the contractors.